

Mandrino allargatubi a 5 rulli per tubi e curve in acciaio inox a tabelle British Standard 1864:1966

Tube expander with 5 rolls for stainless steel tubes and bends according to British Standard 1864:1966 tables

Dudgeon évaseur à 5 galets pour tubes et coudes en acier inox suivant BS 1864:1966

Selbsttätige Rohrwalze mit 5 Rollen für Rohre und Bögen aus rostfreiem Stahl nach Tabellen British Standard 1864:1966



Rulli Rolls Galets Rollen	L _t		L _u	
	inches	mm	inches	mm
R-BS 1"	1.339	34,0	1.102	28,0
R-BS 1.1/2"	1.417	36,0	0.102	28,0
R-BS 2"	1.417	36,0	0.102	28,0
R-BS 2.1/2"	1.653	42,0	1.260	32,0
R-BS 3"	1.772	45,0	1.339	34,0
R-BS 3.1/2"	2.008	51,0	1.575	40,0
R-BS 4"	2.008	51,0	1.575	40,0

Tubo Tube Tube Rohr					Espansione Expansion Expansion Walzbereich		Mandrino Tube expander Dudgeon Rohrwalzen	Rulli Rolls Galets Rollen	Spina Mandrel Broche Dorn	Mandrinatrici consigliate Suggested rolling machines Dudgeonneuses conseillées Empfohlene Rohrwalzanlagen		
de	sp	di								Elettriche Electrical Électriques elektrisch		Pneumatiche Pneumatic Pneumatiques pneumatisch
inches mm	inches mm	inches mm			inches mm		Cod.	Cod.	Cod.	inches mm		
1" (25,4)	0.049 1,25	0.902 22,9			0.866÷0.984 22,0÷25,0		BS 1"	R-BS1"	S-BS 1"	0.315" (8,0)	F90 M4/V MS/60	Macrol 450
1.1/2" (38,1)	0.049 1,25	1.402 35,6			1.339÷1.496 34,0÷38,0		BS 1.1/2"	R-BS1.1/2"	S-DIN40-BS 1.1/2"	0.472" (12,0)	F90 M4/L M4/V	Macrol 450
2" (50,8)	0.049 1,25	1.902 48,3			1.850÷2.008 47,0÷51,0		BS 2"	R-BS2"	S-DIN50-BS 2"	0.551" (14,0)	F90 M4/L MG/49	Macrol 200
2.1/2" (63,5)	0.059 1,50	2.382 60,5			2.323÷2.520 59,0÷64,0		BS 2.1/2"	R-BS2.1/2"	S-DIN65-BS 2.1/2"	0.630" (16,0)	F90 M4/L MG/49	Masterrol 180
3" (76,2)	0.059 1,50	2.882 73,2			2.795÷2.992 71,0÷76,0		BS 3"	R-BS3"	S-DIN80-BS 3"	0.787" (20,0)	F90 MG/49	Masterrol 180
3.1/2" (88,9)	0.079 2,00	3.342 84,9			3.307÷3.504 84,0÷89,0		BS 3.1/2"	R-BS3.1/2"	S-DIN90-BS 3.1/2"	0.866" (22,0)	F90 MG/49	Masterrol 90
4" (101,6)	0.079 2,00	3.843 97,6			3.780÷3.976 96,0÷101,0		BS 4"	R-BS4"	S-DIN100-BS 4"	0.866" (22,0)	F90 MG/36	Masterrol 90

MTT-BS

Morsetto per taglio tubi da BS 1" a BS 4"

Clamping lug for cutting tubes from BS 1" to BS 4"
Mâchoire pour coupe tubes de BS 1" à BS 4"
Klemme für Schnitt der Rohre von BS 1" bis BS 4"

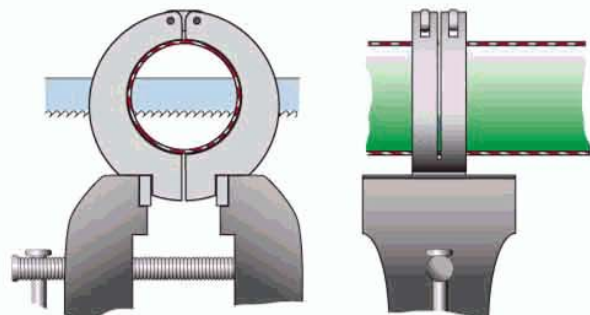

Fig. TE82-F1

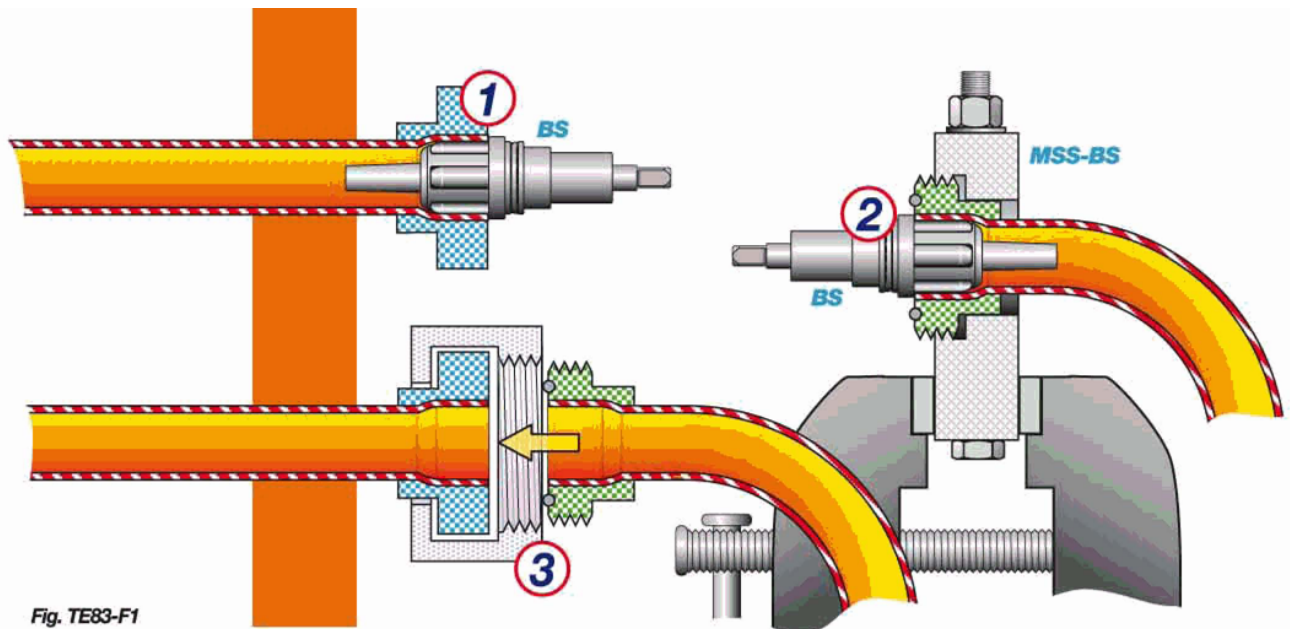

Fig. TE83-F1

MSS-BS

Morsetto di serraggio singolo per mandrinare tubi da BS 1" a BS 4".

Single clamping lug for rolling tubes from BS 1" to BS 4".

Mâchoire de serrage individuel pour dudgeonner tubes de BS 1" à BS 4".

Einfach-Klemme für das Einwalzen von Röhren von BS 1" bis BS 4".

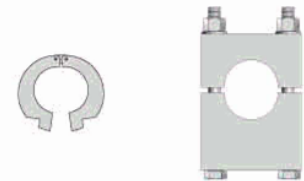

<i>d_e</i> inches mm	MTT-BS Cod.	MSS-BS Cod.
1" (25,4)	MTT-BS 1"	MSS-BS 1"
1.1/2" (38,1)	MTT-BS 1.1/2"	MSS-BS 1.1/2"
2" (50,8)	MTT-BS 2"	MSS-BS 2"
2.1/2" (63,5)	MTT-BS 2.1/2"	MSS-BS 2.1/2"
3" (76,2)	MTT-BS 3"	MSS-BS 3"
3.1/2" (88,9)	MTT-BS 3.1/2"	MSS-BS 3.1/2"
4" (101,6)	MTT-BS 4"	MSS-BS 4"

VD-DN

Mandri allargatubi per la mandrinatura del seggio nelle valvole

Tube expanders for rolling valve seats
Dudgeons évaseurs pour le dudgeonnage du siège dans les soupapes
Selbsttätige Rohrwalzen für das Einwalzen des Ventilsitzes

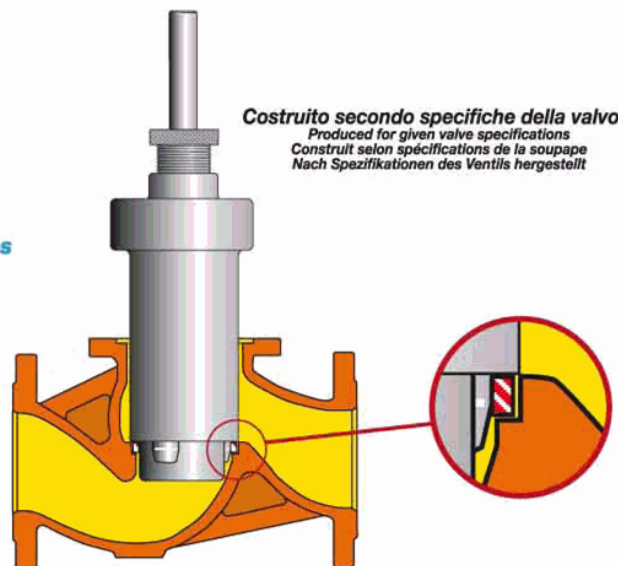

Costruito secondo specifiche della valvola
Produced for given valve specifications
Construit selon spécifications de la soupape
Nach Spezifikationen des Ventils hergestellt

Fig. TE83-F2